

# Budget security public administration mechanisms in Ukraine

**Svirko Svitlana<sup>1</sup>, Dyka Olena<sup>2</sup>, Dovgalyuk Vita<sup>3</sup>,  
Kuchmenko Vitalii<sup>4</sup>, Trostenyuk Tetiana<sup>5</sup>**

<sup>1</sup> *Doctor of Economic Sciences, Doctor of Sciences in Public Administration, Professor  
Zhytomyr State Polytechnic University*

<sup>2</sup> *Candidate of Economic Sciences, Associate Professor  
Zhytomyr State Polytechnic University*

<sup>3</sup> *Candidate of Economic Sciences, Associate Professor  
Zhytomyr State Polytechnic University*

<sup>4</sup> *Candidate of Economic Sciences, Associate Professor  
Zhytomyr State Polytechnic University*

<sup>5</sup> *Doctor of Philosophy, Associate Professor  
Zhytomyr State Polytechnic University*

---

## Abstract

The article solves the scientific task of developing theoretical and methodological provisions and practical mechanisms for the public administration of budget security in Ukraine. The description of budget security is worked out, the essence of state management of budget security is revealed, its functions, principles, methods are developed. It justifies the allocation of mechanisms of State management of budgetary security by blocks: «Frame-support» (hierarchical-coordination, information-communication); «Functional-nodal» (directive-functional, political-strategic, financial-budgetary); «Social security» (motivational-stimulating, moral-ethical, socio-psychological). A model of an integral mechanism of public administration of budgetary security is formed as a formalized idea of an inseparably united set of various mechanisms of public administration of the latter in the general outline of components. The institutionalization of public administration of budgetary security is carried out in the context of subjects of direct and indirect leading action. The hierarchical coordination mechanism of public administration of budgetary security is developed in the context of three types of managerial relations: subordination, coordination, re-coordination. The classification of information flows of management information has been developed and an information and communication mechanism for public administration of budget security has been formed with an appropriate canvas of components. The procedure for making managerial decisions within the framework of directive-functional, political-strategic, financial-budgetary mechanisms has been developed, and a complex functional-nodal mechanism of public administration of budget security has been formed with the corresponding canvas of components. The socio-psychological mechanism of public administration of budgetary security has been formed, including: the governing bodies of the process of training the public community in the field of public administration of budgetary security; participants in the process of preparing a public community in the field of public administration of budget security by type of education; canvas components.

*Keywords:* budget security; mechanisms of public administration; state management of budget security.

---

Corresponding author:

<sup>1</sup> ORCID: <https://orcid.org/0000-0001-9157-4672>

<sup>2</sup> ORCID: <https://orcid.org/0000-0002-0800-3498>

<sup>3</sup> ORCID: <https://orcid.org/0000-0003-2732-8818>

<sup>4</sup> ORCID: <https://orcid.org/0000-0003-3822-3528>

<sup>5</sup> ORCID: <https://orcid.org/0000-0001-7130-7454>

© 2024 S.Svirko, O.Dyka, V.Dovgalyuk, V.Kuchmenko, T.Trostenyuk

doi: [https://doi.org/10.26642/ppa-ppa-2024-2\(10\)-18-32](https://doi.org/10.26642/ppa-ppa-2024-2(10)-18-32)

## 1. Introduction

Public administration in Ukraine is at the stage of active mastering of a wide object spectrum, which is explained by the traditionally extremely significant role of our state in society. One of its central segments under modern conditions is state security in the entire structure of its components. The latter is identified differently, however, the intersection point of vector scientific approaches is economic security. Among other elements of economic security, a prominent place is occupied by budgetary security, the nature of which determines its original position in the totality of other types and subspecies of state security: it is about its financial and security role. Such a prominent characteristic of budget security should automatically attract the attention of not only practitioners, but also scholars in the field of public administration. However, modern approaches to the study of its problems in the state-managerial aspect are distinguished by a certain unsystematic and fragmentary, and the scientific mastering of single aspects of the latter without taking into account its fundamental essence, connection and subservience certainly provides an increase in exclusively scholastic knowledge. At the same time, an understanding of the true nature of the concept of «budget security», an in-depth study of its basic provisions, and correct identification of factors, threats and risks will make it possible to form scientifically grounded theoretical and methodological positions of state management of budget security, which, in turn, will ensure the implementation of the task of developing effective mechanisms for state management of budget security. This task is dictated by the practice of public life, in particular: the disappointing financial situation of our country and the difficult political situation in it, the global economic recession and the consequences of the coronavirus disease-2019 pandemic and other determinants. In view of the above, conducting a thorough comprehensive scientific study of the problems of public administration of budget security is extremely necessary and relevant.

## 2. Literature review

### 2.1. The concept of budget security as a component of national security

Studies of modern scientists in the developed world demonstrate the lack of unity of approaches to the identification of components of national security, focusing recently on the most critical positions, in particular: extremism and radicalism, cyber security, social security, communication security, etc. (Jayakumar S.) [13].

At the same time, traditional national security об'єкти remain equally important (Osisanya) [24]: economy, nutrition, health, ecology, politics, personality and community in the focus of law enforcement problems, as well as ethnic and religious problems.

A review of well-known periodicals on world-class national security over the past more than ten years testifies to the elaboration by the authors of these publications of such topics in the context of national security: climate change, domestic terrorism, radicalism, cybersecurity, nuclear weapons, piracy, space, refugees (Inquiries Journal, 2011–2023) [22]; social media, epidemic, human rights, domestic terrorism and extremism (Harvard National Security Journal, 2011–2023); weapons, extremism, energy, corruption, domestic terrorism (National security: News, Analysis and Opinion from Politico, 2011–2023) [23].

However, the issue of a clear definition of the structured nature of «national security» is not considered by the authors, and the position of budget security is not identified and is not submitted to the object of research in general.

The appeal to the domestic legal field indicates the separation of such structural components of national security (Law of Ukraine «On National Security of Ukraine», 2018; National Security Strategy of Ukraine, 2020; Methodological recommendations for calculating the level of economic security of Ukraine, 2013) [26–28]: human development security, military security, public security, defense industrial security, energy security, environmental security, biosecurity, information security, cybersecurity, foreign policy security, state security, border security, food security, economic security; in turn, economic security as part of financial security includes budget security, characterized as «a state of ensuring the solvency and financial stability of public finances, which allows public authorities to perform their functions as efficiently as possible» (Methodological Recommendations for Calculating the Level of Economic Security of Ukraine, 2013) [28].

Recent publications by domestic researchers indicate a certain unsystematic nature in the formation of national security components (Chumak; Bear; Seryogina; Berdansky; Kuc; Medvid) [6, 19, 21, 30]; against the background of such results, the most «recent» studies attract attention, in which the need for separation within the framework of national security is logically substantiated and motivated: the security of national governance; political security; economic security; military security; security of public and legal order; social and humanitarian security; information and communication security; resource and environmental safety; technical and technogenic safety; international diplomatic security (Suprunova; Evdokimov) [14]. It is worth noting that all domestic authors unequivocally support the point of view of including budget security in economic security (Bogma; Prokazyuk; Postolenko; Dets; Demenok; Baranovsky; Zveruk; Kolesnik; Cap; Evdokimov and others; Gritsyshen and others) [1–4, 8, 9, 11, 17, 18, 25, 29, 32, 33]. This unity of approach allows us to assert the importance and equality of budget security among other components of national security.

### 2.2. The concept of public administration of budget security

Budget security, as a complex phenomenon of multi-vector influence, attracts more and more attention of specialists of various profiles of practical and theoretical level. This trend is natural given the daily increase in threats, risks and negative factors of influence both on the budget system and the process in particular, and on the public finance system as a whole. In the context of the development of new mechanisms of public administration against the background of the voiced processes, of particular importance is the theoretical understanding and justification of budget security in the focus attention of public administration as a component of public administration of state security. Despite the importance of considering issues of public

administration of budget security, it should be noted that research on this scientific direction is extremely limited (Lutsyk-Dubova; Borodiy; Bogma; Moshenskiy; Butuzov; Yakovenko; Tarasova; Evdokimov and others; Gritsyshen and others) [5, 7, 11, 12, 14–16, 20]. Paying tribute to the contribution of these scientists and certain achievements in the relevant scientific field of the latter, a comprehensive understanding and applied vision of the mechanism of public administration of budget security was not formed. At the same time, in the urgent need to form a capable methodological and organizational superstructure of public administration in the field of budget security, the declared object of research is considered extremely relevant, and the research itself is timely.

### **3. Identification of previously unresolved questions and formulation of study hypotheses**

Despite some achievements of domestic scientists in the field of budget security, none of the authors formed a comprehensive mechanism of public administration of budget security as an element of the general system of public administration in Ukraine.

### **4. Data and methodology**

The information base of the study was the data of economic statistics and financial reporting on the implementation of the State budget.

The methodological basis of the study was general philosophical, general scientific methods of theoretical and empirical levels, as well as special methods of cognition of phenomena and processes within the framework of public administration of budget security. To determine the place of budget security in state security, methods of theoretical generalization, comparative analysis and concretization, induction and deduction, grouping, abstraction are applied. In order to conceptually clarify budget security and develop its meaningful characteristics, methods of theoretical generalization, systematization, comparative analysis and concretization, comparison, grouping, induction and deduction, cause and effect relationships, logic and classification are used. With the help of theoretical generalization, analysis and synthesis, modeling and formalization, logic and classification, the regulatory model of state management of budget security has been developed. The formation of the theoretical foundations of public administration of budget security became possible through the use of methods of theoretical generalization, analysis, synthesis, grouping, induction and deduction, systematization, abstract-logical method. Development of methodological provisions of state management of budget security is carried out using methods of theoretical generalization and systematization, modeling, synergistic approach, modeling, comparative analysis and concretization, formalization. The formation of the institutional model of public administration of budget security was facilitated by methods of theoretical generalization, analysis and synthesis, abstract-logical method, modeling, formalization. In the process of developing practical elemental mechanisms of public administration of budget security, methods of analysis and synthesis, induction and deduction, formalization, modeling, concretization, abstract-logical method, logic and classification are applied.

### **5. Purpose of publication**

On the basis of elaboration of theoretical and methodological principles of both budget security and public administration of budget security to form an integral mechanism of public administration of budget security of Ukraine and its components.

### **6. Results and discussions**

The formation of mechanisms for public administration of budget security is not a possible theoretical basis. In order to develop the theoretical positions of state management of budget security, on the basis of the analysis of approaches to the definition of the concept, direct subordination of budget security, taking into account the requirements for the activities of state institutions and entities, based on the laws of formal logic, the concept of «budget security» is interpreted as a state of financial security of the sector of general public administration, characterized by the solvency and financial stability of the state, as an economic entity that enables institutional units of this sector to exercise powers to perform state functions as efficiently and effectively as possible in the face of a changing environment, external and internal threats [16, 31]. This approach provides both a correct interpretation of budget security within the domestic and world managerial and economic theory and practice, but also a focus on the most general object-subject features of the concept. To continue the study of the basic foundations of budget security, it is proposed to identify as follows the following set of them: the purpose of budget security is to develop optimal in structure and internal content and resistance to various threats to the State and local budgets; the subjects of budget security are the relevant executive authorities and local self-government within the sector of general public administration; the subject of budget security is the budget system, the budget process, the budget mechanism; the objects of budget security are elements of the budget system, the budget process, the budget mechanism [16, 31].

In order to systematize the multi-vector role of budgetary security in the life of society in the context of object attention of public administration, the external, internal and general sphere of its influence is motivated, defined, within which 13 positions are allocated. With their consideration, the identification of the place of budgetary security in the modern world as: an element of ensuring the functioning and existence of the institution of a sovereign state; component of a multi-element system of state security; object of public administration; a public finance management tool, including the budget system and budget process; means of monitoring the state of solvency and financial stability of the state in terms of budget resources and funds; factor of economic development of the country and economic entities; determinants of social security of citizens of the country;

information source of society regarding relevant data on the state of use of funds of its individuals – participants in replenishment of the revenue side of budgets; type of professional activity; educational and scientific direction [31, 32]. It identifies a set of functions of budgetary security (institutional, managerial, protective, control and indicative, economic, social, informational, activity, scientific and cognitive) and corresponding tasks. Within the framework of the formation of the classification of budget security, the allocation of 4 features is motivated, according to which the grouping by: budget level is allocated; budget elements; functions of the state; sphere of influence.

An important task within the framework of the formation of mechanisms for public administration of budget security is the regulatory support of the latter, which, in fact, should prescribe the key provisions of such mechanisms. Based on the general theoretical positions of budget security and public administration of the latter, focusing on the requirements of the organization of any process or activity, we propose the following classification grouping of regulations of the sphere of governing influence on budget security: 1) by object components: security of the budget system, security of the budget process, security of the budget mechanism; 2) by budget level: regulations of the sphere of influence on the State budget; regulations of the sphere of influence on local budgets; universal regulations; 3) by the degree of impact: total impact; providing action; profile impact; special impact; 4) on the functions of public administration: regulations for the implementation of the planning/forecasting function; regulations on the implementation of the organization's function; regulations on the implementation of the motivation function; regulations on control function implementation. Reasoned classification model of regulations of public administration of budgetary security, the central position in which the fourth feature plays – on the functions of public administration.

A model of regulatory support for public administration of budget security has been formed, which provides for the allocation of four interrelated blocks: regulations for planning/forecasting budget security; regulations on the organization of achieving budget security; regulations on motivation to achieve budget security; regulations for monitoring the achievement of budget security. An analysis of all identified regulatory legal acts led to the conclusion that there were no necessary provisions for regulating the process of public administration of budget security [31, 32]. Their formation substantiated and developed proposals to amend the Constitution of Ukraine, the Law of Ukraine «On National Security of Ukraine», the Budget Code of Ukraine, the Order of the Ministry of Economic Development and Trade of Ukraine «On Approval of Methodological Recommendations for Calculating the Level of Economic Security of Ukraine». Their final implementation will consolidate the necessary provisions on public administration of budget security in all regulatory documents that directly or indirectly regulate issues of budget security.

Development of real effective mechanisms, procedures and rules of public administration of budget security is not possible without a scientifically grounded basis, which in front of everything consists in terminological identification of the concept itself «public administration of budget security», which is reasoned to be understood as a separate direction of public administration of state security, within which, through a set of state authorities and other entities whose activities are fully or partially aimed at achieving, supporting, developing and protecting the country's budget security, a purposeful managerial influence of the state is carried out to ensure the functioning and development of all its functional spheres [31]. This approach provides a correct interpretation of the concept of «public administration of budget security» both within the framework of the science of public administration and state security in general and economic, financial, budget security in particular, as well as an emphasis on the exclusive chain-securing role of budget security among other types of state security.

In the process of studying the nature of public administration of budget security, its essence is revealed, consisting in a tetrahedral form manifestation [31]. As a system of state management of budget security, it is a complex subsystem of state management of state security, within which its theoretical and methodological part (including mechanisms) affect its nucleus with their tools (represented by the relevant subject-object field and the totality of its managerial relations), functioning in the conditions of the action of internal and external factors of the subsystem, in order to achieve the necessary and sufficient level of budgetary security for the effective and productive functioning of the institution of the state. The proposed formalization of the system of public administration of budget security the theory of public administration of budget security in the form of conceptual apparatus, purpose, functions and tasks forms the basis and a certain functional query on the methodology of public administration of budget security, as well as, through the identification of the above positions (including subject-object field) forms a clear internal system framework. As a process, state management of budget security is a special type of management process to ensure the functioning of the state in terms of its budget security, which has a spherical structure of a double circle, the first of which is represented by a set of stages of the functioning of the object – budget security, and the second – by a set of stages of the influence of entities on the object. On the development of a formalized imagination about the process of the same name, its organizational stages and stages of influence on the managed object are determined. As a type of activity, public administration of budget security is a purposeful set of actions in its unity, which is subordinated to social motives and goals, and also includes multidisciplinary skills and abilities, the implementation of which (accompanied by appropriate support) within the framework of the functioning of both the system and the process of public administration of budgetary security, aimed at achieving the main goal – ensuring an appropriate level of budgetary security of the country. It is proved that public administration of budgetary security is also a certain vector scientific and cognitive direction of public administration in general and public administration of state security in particular, which is interspecific and in a certain way intersectoral in nature and studies and processes within the axiological, cognitive and technological components of both the system and process of the same name, and activities in order to form and systematize knowledge on public administration of budget security.

For further development of the theoretical foundations of public administration of budget security, it is substantiated that the functions of public administration of budget security are a system of two-dimensional content-target elements of the governing influence of the relevant subjects of public administration of budget security on budget security itself, as well as the external governing influence of the result of public administration of budget security on society [31]. At the same time, internal influence

functions (general) are classical management functions in general, through which subjects purposefully influence the object – in this case, budget security – in order to achieve the appropriate level of the latter (planning/forecasting, organization, motivation, control). Functions of external influence (specific) represent a vector effective direction of the results of internal control influence on the external environment within society (Table 1) [31].

Table 1  
Functions of external influence of public budget security administration

<b>Functions</b>	<b>Tasks</b>
Institutional	Ensuring the existence of the institution of the state and the functioning of institutions of the general government sector by achieving and maintaining the required level of budget security
Managerial	Formation of budget security indicators for decision-making in the field of public administration in general and in the context of individual areas
Protective	Protection of the budget system, process, mechanism of the country from threat, as well as the rights of citizens of Ukraine as participants in the budget process as taxpayers
Financial	Promoting the implementation of plans to finance the most important functions of the state
Informational	Providing society within the implementation of the principle of publicity on public administration with relevant reliable and credible information on the state of budget security of the country
Activity	Development of a professional direction in the field of public administration of budget, and hence financial, economic and state security
Scientifically-Cognitive	Development of the science of public administration of budget security

In the context of the development of methodological foundations for public administration of budget security, proposals were made to divide the principles of public administration of budget security into the principles of its methodology and organization [31]; at the same time, the organization of public administration of budget security is proposed to be understood as a set of methods, methods and means of streamlining, optimizing and increasing the efficiency of the functioning of public administration of budget security in all its forms. The article justifies the election as the basis of the principles of the methodology of public administration of budgetary security of the principles of the methodology of public administration, expanding them with specific, such as: multifaceted form manifestation; intersectoral; multidisciplinary competence; information efficiency. Regarding the principles of organization of public administration of budget security, it is proposed to allocate 2 levels of such principles, namely general and form presentation, while the latter are divided into 4 groups depending on the presented options for identifying public administration of budget security, highlighting groups of principles for the organization: systems of public administration of budget security, the process of public administration of budget security, activities on public administration of budget security and scientific direction on public administration of budget security.

In order to form a methodological superstructure of public administration of budget security, a definition of a «mechanism of public administration of budget security» has been formed, by which it is proposed to understand the set of interrelated methodological and organizational components that, in their logical causal and effective connection, reflect the actual content and structural content of the above system and the sequence of the above process in space and time, through which the guiding influence on budget security is carried out [31]. The presented dictionary design allows to take into account the corresponding subcontracting relationship of all the declared concepts-inclusions, scientific and practical levels of study of object phenomena and processes, the relationship of methodological and organizational components, the static-dynamic content of the system / management process.

Based on the elaboration of approaches to the definition of mechanisms of public administration, taking into account the proposals of the authors already set out, it is proposed to allocate the following mechanisms of public administration of budget security in the context of the following blocks: «Frame-support mechanisms» (hierarchical-coordination – mechanism of subordination ratio of subjects of public administration of budget security and their interdepartmental coordination and interaction; information and communication – a mechanism for obtaining, processing and transmitting information within the framework of public administration of budget security); «Functional-nodal mechanisms» (directive-functional – a mechanism for implementing general management decisions to ensure budget security both in the context of achieving the goal directly and organizing the achievement of the latter; political and regulatory – a mechanism for shaping the policy of public administration of budget security and regulatory support of the latter; financial and budgetary – a mechanism of financial management actions to ensure budget security); «Social security mechanisms» (motivational-stimulating – a mechanism for motivating and stimulating employees, whose functional responsibilities include ensuring budget security; moral and ethical – a mechanism for ensuring compliance with moral and ethical standards in the process of implementing state management of budget security; socio-psychological – a mechanism for persuading about the necessity and proper involvement of citizens in public administration of budget security, as well as the importance of the latter).

The necessity and possibility of forming, and therefore the model of an integral mechanism of public administration of budgetary security is formed as a formalized idea of an inseparably united set of different mechanisms of public administration of the latter in the general outline of components (Fig. 1) [31].

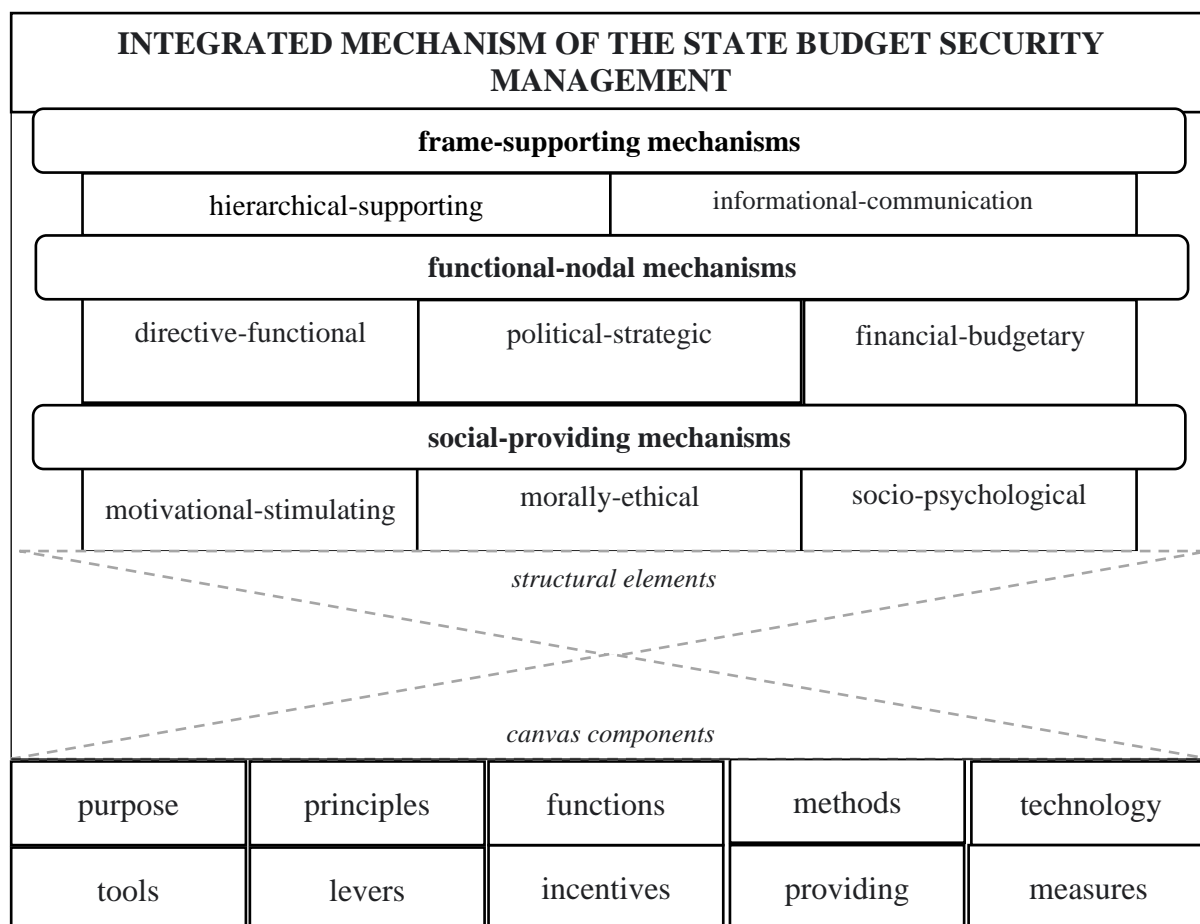

Fig. 1. Model of the integrated mechanism of public administration of budgetary security

Further development of the methodological superstructure of public administration of budgetary security is characterized by the concept of state policy in the field of budgetary security, which is proposed to understand the purposeful, continuous and organized activities of state institutions in the field of budgetary security in order to achieve it, stabilize and grow. A classification of state policy in the sphere of budget security is formed according to the following features: by the level of budget; by budget elements; by functions of the state; by sphere of influence; by time period. The principles of state policy in the field of budget security, in particular: scientific validity; the rule of law and legality; publicity and transparency; heredity and continuity; priority of goals; completeness of coverage; complexity; correlations; synergy of structural elements; effectiveness and efficiency; accountability and control.

In the process of studying the provisions of institutionalization in the context of specific object orientation, it is proposed to understand under the institutionalization of public administration of budget security the process of identification of relevant institutions, formalization and systematization of fundamental provisions (object, goal, principles, functions, tasks, forms, norms), their connections, communications within the framework of public administration of budget security in particular and in general, in general or in the context of the relevant focus request. Based on the elaboration of the current domestic regulatory and legal field, the institutionalization of public administration of budget security in the context of subjects of direct managerial action was carried out (President of Ukraine – hereinafter PU; National Security and Defense Council of Ukraine – hereinafter NSDCU; Verkhovna Rada of Ukraine – hereinafter VRU; Cabinet of Ministers of Ukraine – hereinafter CMU; Security Service of Ukraine – hereinafter SBU; Ministry of Finance of Ukraine – hereinafter MFU; Ministry of Economy of Ukraine – hereinafter MEU, Bureau of Economic Security of Ukraine – hereinafter BESU; Accounting Chamber of Ukraine – hereinafter ACU; National Agency of Ukraine for Civil Service – hereinafter NAUSS) and subjects of indirect management action: State Treasury Service of Ukraine; State Audit Office of Ukraine; State Fiscal Service of Ukraine; State Customs Service of Ukraine (hereinafter – STSU, SAOU, SFSU, SCSU, respectively). Proposals have been made to clarify the powers of the following public administration entities of budget security: CMU, SBU, MFU, MEU, BESU, ACU. The conducted institutional analysis of the subjects of public administration of budgetary security of direct and indirect action allowed to form a dynamic-functional institutional model of public administration of budgetary security (Fig. 2), demonstrating the implementation of its general (internal influence) and special (external influence) functions in their dynamics within the institutional environment of the latter [31]. Its construction will contribute to the formation of clear mechanisms of public administration of budget security, and therefore increase the efficiency and effectiveness of public administration of budget security.

In order to build a hierarchical-coordination mechanism within the framework of public administration of budgetary security, the formation of the latter is motivated in the context of subjects of public administration of budgetary security through the

establishment of appropriate managerial ties between them. In the context of the research object, in order to solve this problem, management relations of PU, VRU, NSDCU, CMU, SBU, BESU, ACU and other subjects of public administration of budget security have been identified and supplemented. Based on this, a hierarchical coordination mechanism for public administration of budget security has been developed in the context of three types of managerial relations: subordination, coordination, and re-coordination (Fig. 3).

The outline of the components of the hierarchical-coordination mechanism of public administration of budget security has been formed, in particular: the goal (formation of managerial ties between the subjects of public administration of budget security to ensure its implementation); principles: hierarchy, rationality, interconnection, simultaneity, consistency, balance, balance, unity, reservation, reliability, clarity, efficiency, response, democracy, publicity; function – organizational; methods – administrative; methods, measures: sighting and other methods of control, vertical distribution of tasks, creation of commissions and committees, horizontal meetings, dissemination of information, negotiations, observation, development of rules, procedures, schedules, norms, plans, regulations, etc., synchronization of actions in time, etc.; technologies – information and analytical and organizational; regulatory support [31].

The introduction of this mechanism will contribute to the development and subsequent streamlining of managerial ties of public administration of budget security.

On the development of the basic provisions of the information and communication mechanism of public administration budget security developed a classification of information flows of management information through its addition of such features and their respective groups: types of information (statistical, administrative, legal, mass, activity, personal); availability (limited, open access) purpose (study, familiarization). The development of the information and communication mechanism of public administration of budget security is motivated by the following successive stages of determination: information data within the system of public administration of budget security; users of input, internal-system and output information of the public administration system of budget security; information entry and exit channels, information movement technologies within the system of public administration of budget security; means for transmitting information on the said system; quality, quantity and value of transmitted information data.

In the process of implementation of these stages: it is motivated to take as a basis the classification of information flows by types, which include such information clusters (legal, statistical, activity, administrative, mass) with giving them characteristics; proving the need to classify the listed information clusters on the basis of time, and therefore decompose into: retrospective, current, perspective; all five information clusters were determined by the proposed characteristics with the allocation of the cluster segment by the time and category of information data; the movement of information flows of said system is identified and visualized; set of users of information, channels of input and output of information, subject technology of information movement and means of information transfer within public administration of budget security are defined.

The information and communication mechanism of public administration of budget security has been formed, within the framework of which the following outline of components has been defined (Fig. 4) [31]: purpose (formation of information connections for obtaining, processing and transmitting information within the public administration of budget security); principles: democracy, alternative, consensus, manufacturability, transparency, neutrality, accessibility, stimulation, openness, cooperation, mutual respect, parameters of information, free of charge; function – organizational, managerial, informational; methods – administrative; methods, activities: exchange of documents, meetings, meetings, negotiations, meetings, sessions, plenums, conferences, hearings, individual reception, informing, consulting, dialogue, partnership, etc.; technologies – information and analytical and organizational; regulatory support.

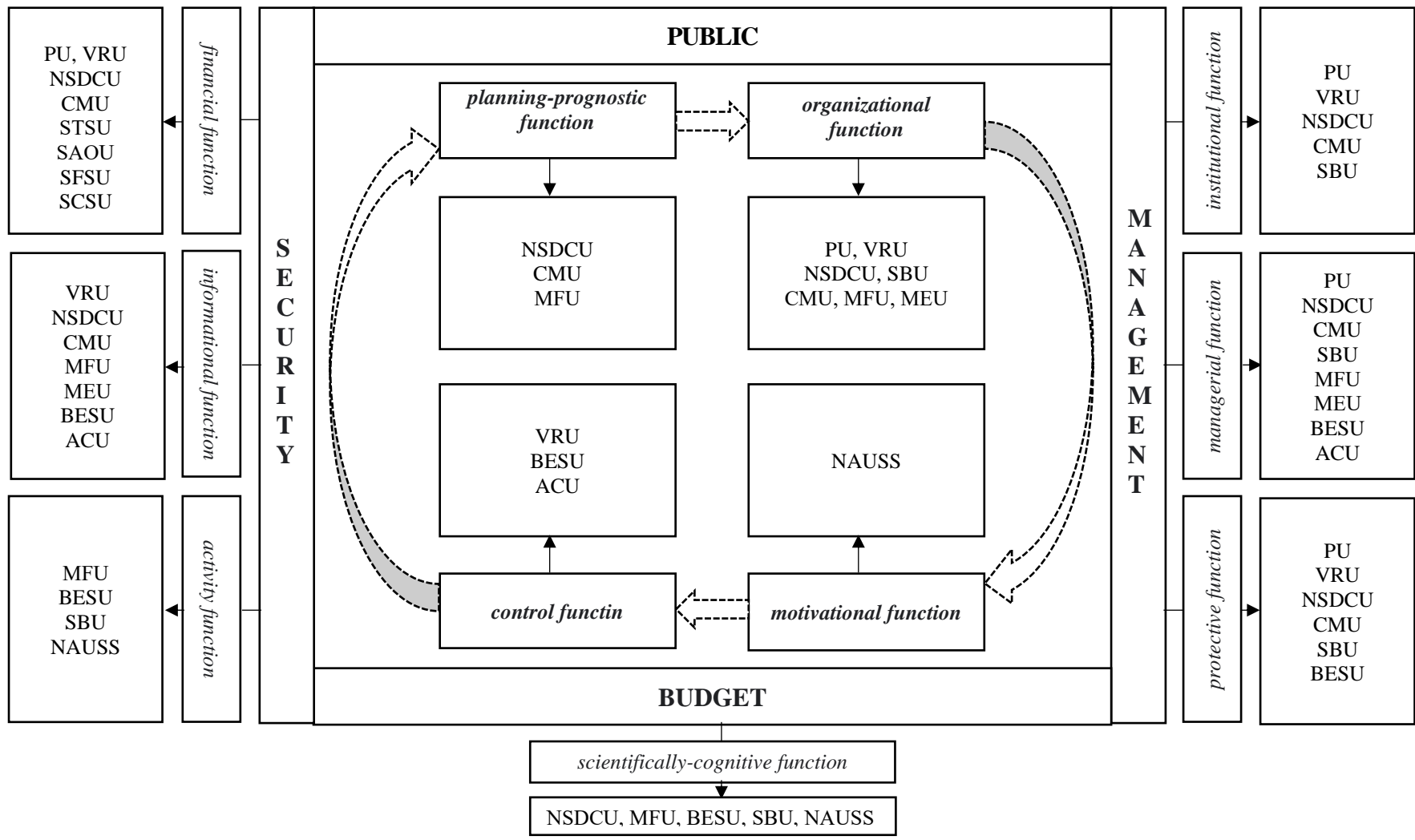

Fig. 2. Dynamic-functional institutional model of public budget security administration



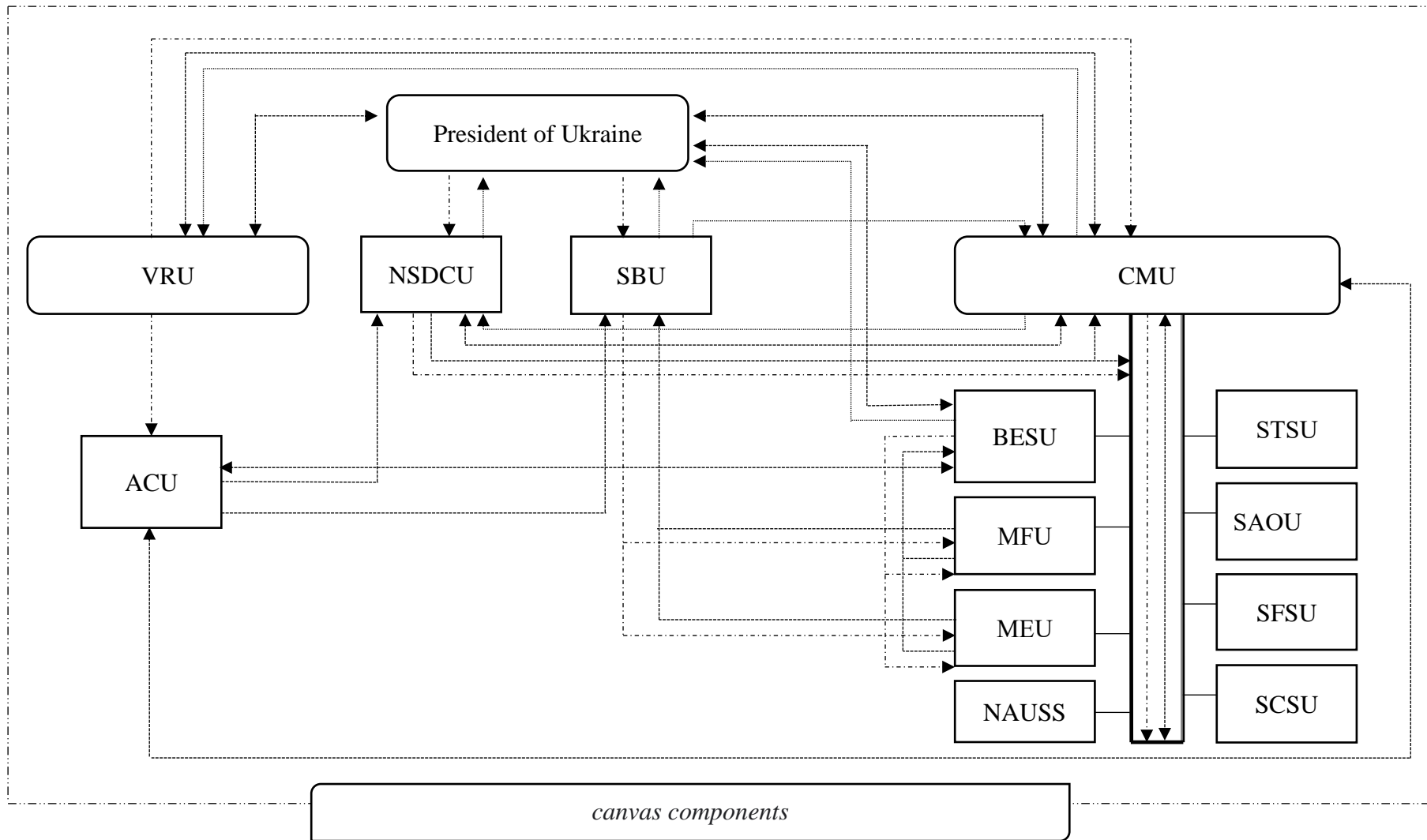

Fig. 3. Hierarchical coordination mechanism of state budget security management  
 (designation: ..... subordination, ----- coordination, ..... reordination, — vertical institutions of executive power (hereinafter – IEP))

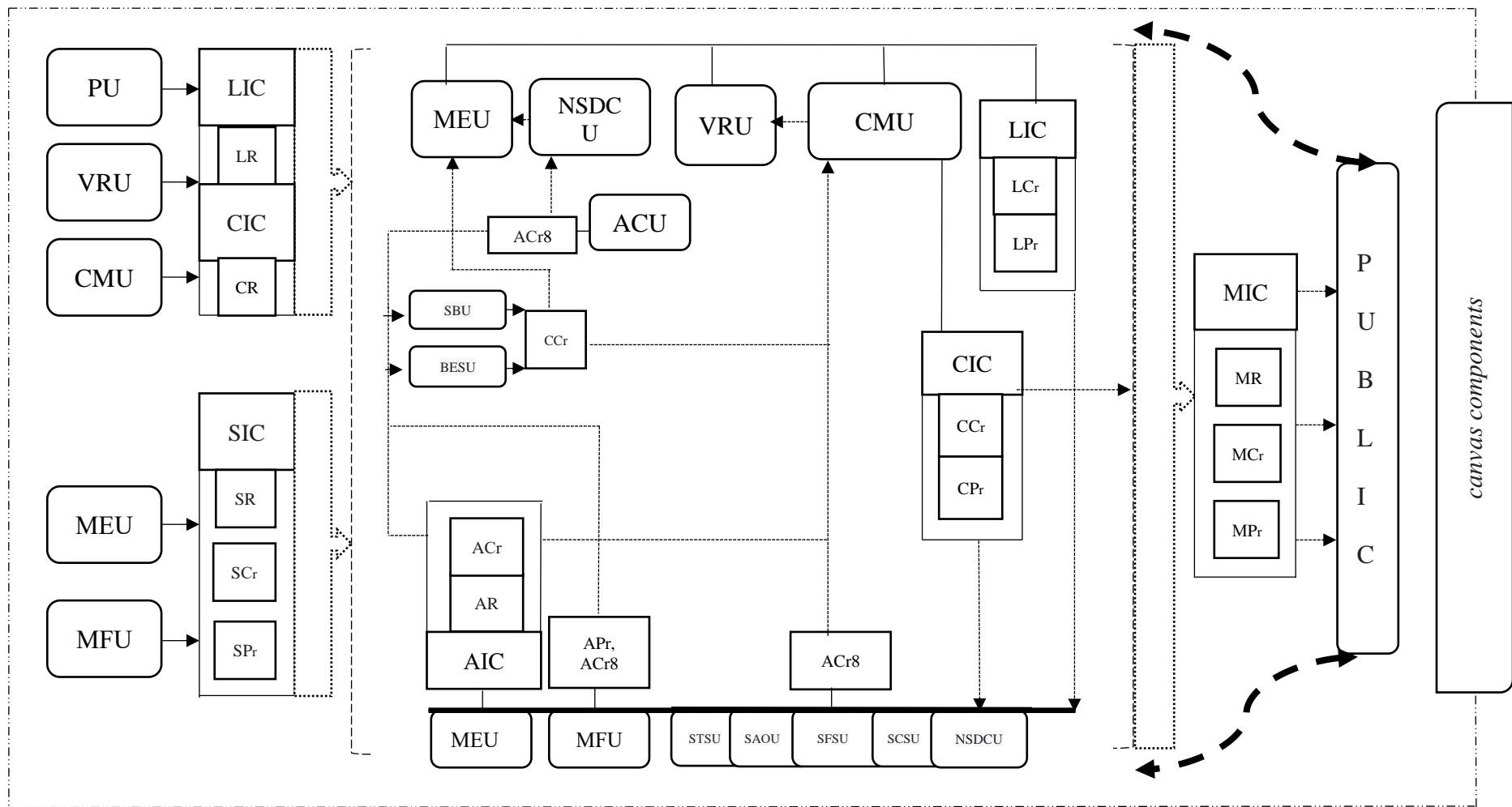

Fig. 4. Information and communication mechanism of state budget security management

(the abbreviation should be understood as: SIC – statistical information cluster; AIC – administrative information cluster; CIC – activity information cluster; LIC – legal information cluster; MIC – mass information cluster; SR – a retrospective segment of the statistical information cluster on the basis of time; SCr – the current segment of the statistical information cluster on the basis of time; SPr – a promising segment of the statistical information cluster on the basis of time; AR – a retrospective segment of the administrative information cluster on the basis of time; ACr – the current segment of the administrative information cluster on the basis of time; APr – a promising segment of the administrative information cluster on the basis of time; CR – a retrospective segment of the activity information cluster on the basis of time; CCr – the current segment of the activity information cluster on the basis of time; CPr – a promising segment of the activity information cluster on the basis of time; LR – a retrospective segment of the legal information cluster on the basis of time; LCr – the current segment of the legal information cluster on the basis of time; LPr – a promising segment of the legal information cluster on the basis of time; MR – a retrospective segment of the mass information cluster on the basis of time; MCr – the current segment of the mass information cluster on the basis of time; MPr – a promising segment of the mass information cluster on the basis of time)

In order to develop functional-nodal mechanisms of public administration of budget security, it is proposed to understand under the adoption of state-management decisions on budget security the scientifically grounded process of forming a professional effective response by the subjects of budget security management to the actual or forecast situation regarding budget security in the country in terms of alternative choice with its consistent legal conclusion [31]. It is recommended that current and long-term public management decisions in the field of budget security.

The stages of the process of making managerial decisions in the field of public administration of budgetary security in general [31] have been formed: preparatory stage (preparation for making a managerial decision in the context of stages): identification, elaboration and prioritization of problems of public administration of budgetary security, including from the point of situational approach; establishment of restrictions and criteria for making management decisions in the field of budget security formative stage (stage of development and adoption of management decisions in the context of stages): formation of a set of alternative management decisions in the field of budget security, their assessment and selection of the optimal one; determination of resource provision, final execution and adoption of a management decision in the field of budget security; implementation stage (stage of implementation of the management decision itself in the context of stages): practical implementation of a management decision in the field of budget security; control over the implementation of the management decision in the field of budget security and adjustment of the latter; assessment of the results of the implementation of management decisions in the field of budget security and the adoption of general organizational decisions on the fact of its implementation.

According to the above-mentioned organizational stages of making state managerial decisions in the sphere of budget security, the procedure for their adoption within the framework of directive-functional, political-strategic, financial-budgetary mechanisms has been gradually and gradually developed.

A complex functional-nodal mechanism of public administration of budget security has been developed in the context of its components [31]: directive-functional, political-strategic, financial-budgetary mechanisms (Fig. 5).

It involves the identification of the situational and conservative field of stages and stages of state management decisions on budget security, as well as subject participation in each of the stages of the latter.

The components of the canvas of this mechanism are recognized in the following interpretation: the goal (formation of the procedure for making state managerial decisions in the field of budget security on the basis of the previously formed concept of provisions and approaches to ensure the implementation of state management of budget security); principles: resource saving, feedback, relevance, strategic thinking, control, efficiency, economy, timeliness, reliability, scientific validity, unity, complexity, flexibility, legitimacy, quantitative and qualitative expression, optimality, orientation, specificity in time, efficiency and timeliness, compliance, selectivity, necessary and sufficient conditions, variety of ways of professionalism, individuality, subject objective probability, compromise, timeliness, adequacy, resource provision, compensation for limited rationality, degree of freedom; functions – planning/forecasting, organizational, control, institutional, managerial, protective, financial, informational, activity; methods – administrative, direct administration methods (including strategic audit), economic (including budget regulation), scientific and analytical; methods, activities: legal, organizational and administrative documents, meetings, minutes, reports, information and analytical, explanatory and official notes, contracts, agreements, regulations, instructions, acceptance certificates, plans, schedules, reports; target, functional, composite, multiple, behavioral approaches in assessing the effectiveness and effectiveness of activities, etc.; technologies – information and analytical and organizational; regulatory support.

For the formation of the socio-psychological mechanism of public administration of budget security, the following target instrumental segments have been proposed for elaboration within it: training, retraining, self-training. On the basis of the above provisions, a socio-psychological mechanism for public administration of budget security has been formed (Fig. 6) [31], including: the governing bodies of the process of training the public community in the field of public administration of budget security; participants in the process of preparing a public community in the field of public administration of budget security by type of education; canvas components.

The latter includes: the goal (formation of maximum public awareness of issues of public administration of budget security in order to create a socio-psychological basis for its active participation in the latter); principles: the rule of law, constructiveness, freedom, democracy, ethics, publicity, transparency, human-centrism, integrity, humanism, scientific justification, complexity, integrity, equality, partnership, accessibility, impartiality, continuity, openness, etc.; function (motivational, informational, scientific and cognitive, activity); methods (administrative, direct administration methods, scientific and analytical); methods, activities: training, counseling, scientific research, informing, agitation, clarification, etc.; technologies (information and analytical and organizational); regulatory support (the above normative acts). The introduction of the developed socio-psychological mechanism of public administration will contribute to the creation of a conscious, logically cumulative age information basis for active public participation in the public administration of budget security.

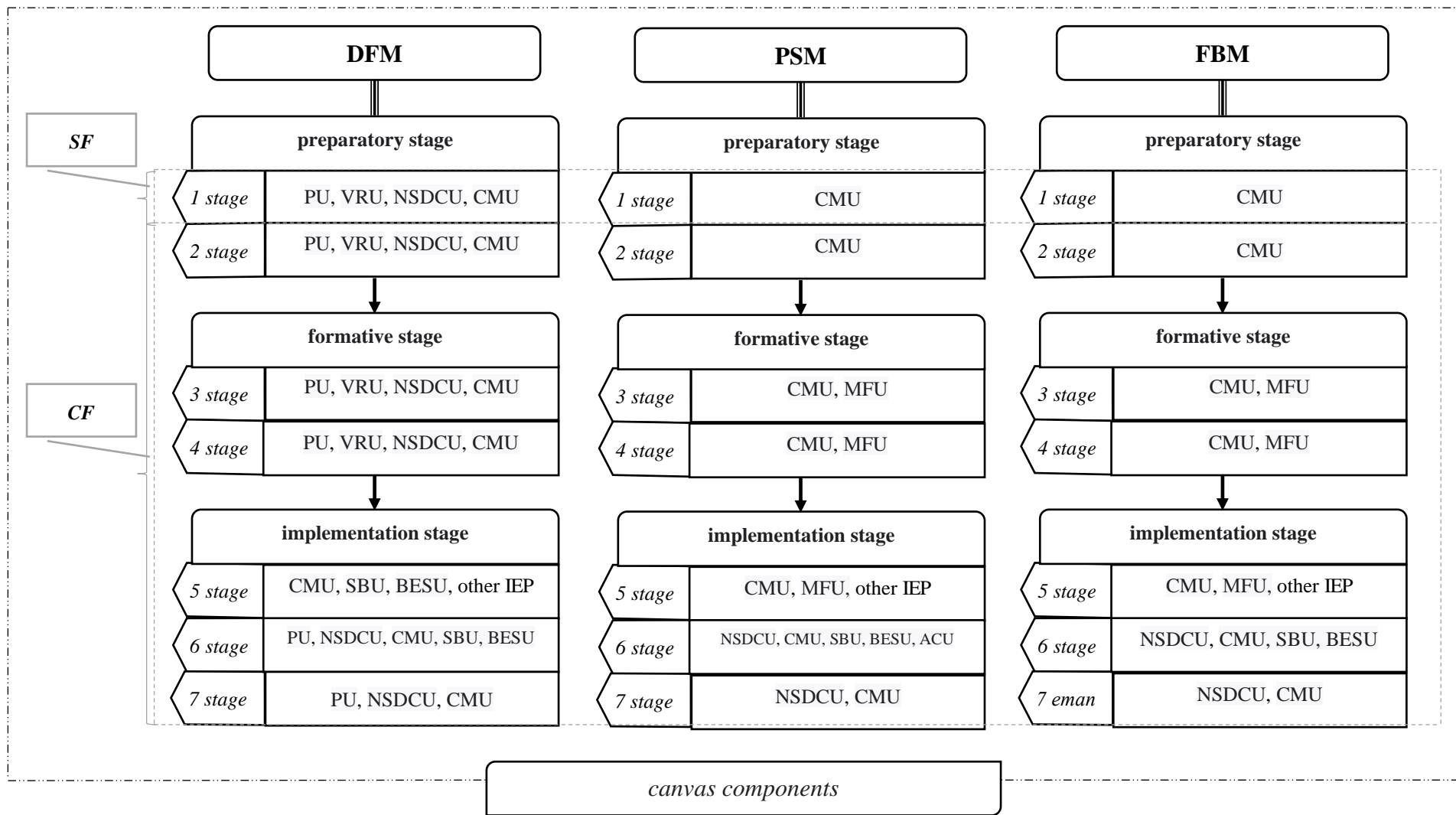

Fig. 5. Complex functional-nodal mechanism of state budget security management  
 (SF – situational field; CF – conservative field; DFM – directive-functional mechanism; PSM – political-strategic mechanism; FBM – financial-budgetary mechanism)

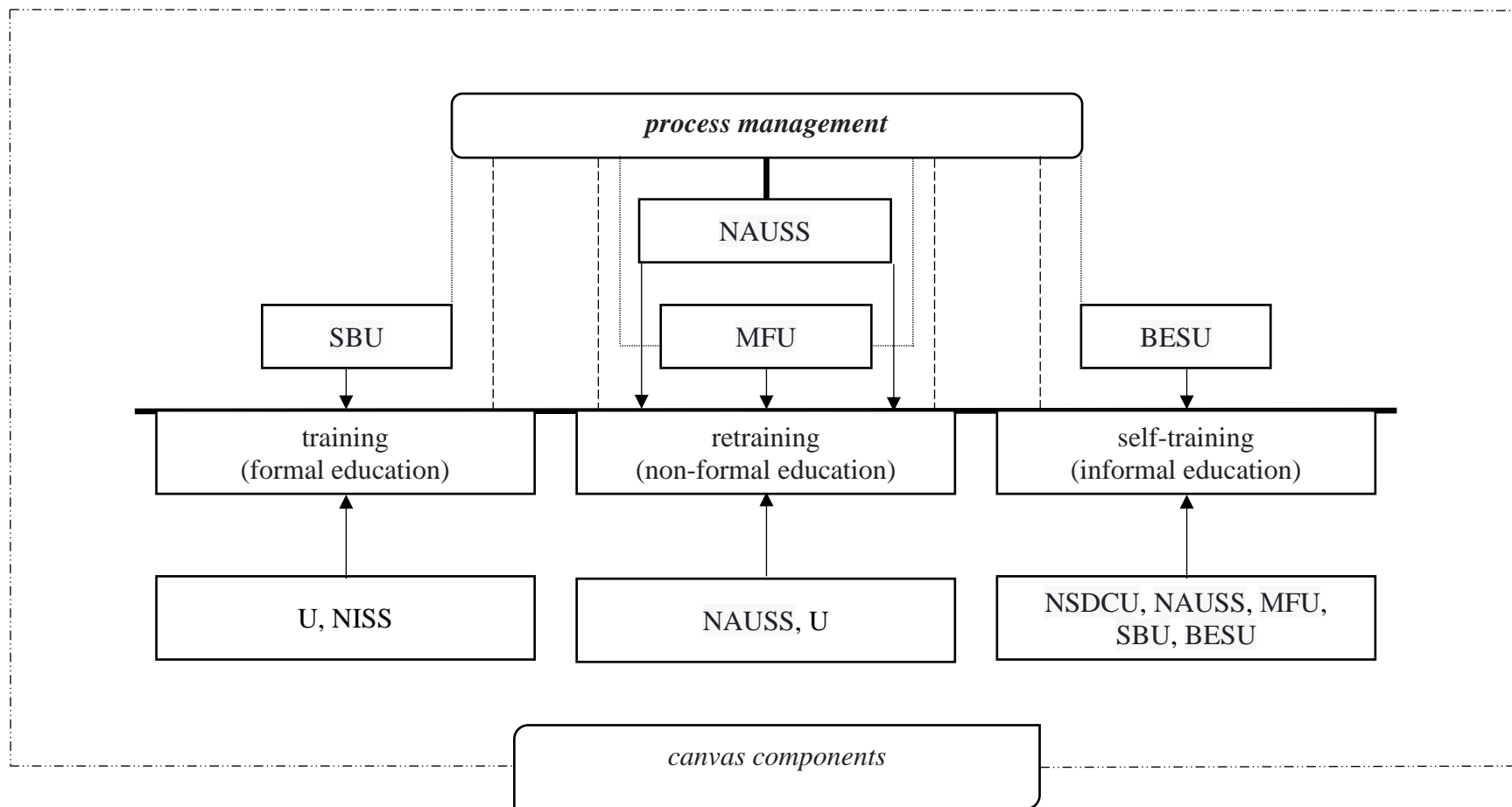

Fig. 6. Socio-psychological mechanism of public administration of budget security  
 (NISS – National Institute for Strategic Studies; U – universities)

## 7. CONCLUSIONS AND RECOMMENDATIONS

Developed conceptual apparatus of public administration budget security, which is presented in the study through a set of the above terms thesaurus of the latter, will further deepen understanding of public administration of its core object – budget security. The developed theoretical and methodological foundations of state management of budget security allowed not only to develop its basis, but also to form an appropriate organizational and methodological superstructure. The introduction of a comprehensive functional-nodal, as well as hierarchical-coordination, information-communication and socio-psychological mechanisms of public administration of budget security will allow training, formation, legitimization and implementation of state-management decisions in the field of budget security at a fundamentally new scientific and substantiated level with maximum effectiveness and efficiency, will promote the development and ordering of managerial relations, will make it possible to create scientifically grounded, optimal and verified information relations of direct and reverse action, will contribute to the creation of a conscious logically cumulative age-related information basis for active public participation within the framework of public administration of budget security, will be the impetus for the development of the scientific and educational basis for activities in the field of public administration of budget security, which will enable the training of highly qualified personnel of the corresponding profile. Implementation of the model of the integral mechanism of state management of budget security as a formalized idea of the inseparably united set of various mechanisms of state management of the latter in the common canvas of components will ensure the formation of an effective and efficient system of current and strategic state management of budget security, and therefore will contribute to strengthening the financial position of the state. The systemic nature of the presented scientific results will make it possible to introduce the existing mechanisms of public administration of budget security in a short time.

At the same time, additional studies require issues of development of budget security assessment, forecasting and planning of the latter, as well as in the context of recent processes – multi-vector determination of risks on the way to achieving budget security and factors of influence on them. With their improvement, the integrated implementation of research results will increase the effectiveness of the public finance management system, and therefore ensure the stabilization and further development of the public finances of Ukraine.

### References:

1. Arkhireiska, N.V. (2015), «Otsiniuvannia stanu biudzhethnoi bezpeky Ukrainy: pozytyvni ta nehatyvni faktory vplyvu», *Ekonomichnyi visnyk DVNZ «Ukrainskyi derzhavnyi khimiko-tehnolohichniy universytet»*, No. 1, pp. 50–55.
2. Baranovskyi, O.I. (2016), «Sutnist i chynnyky biudzhethnoi bezpeky», *Ekonomika i rehion*, No. 2, pp. 20–29.
3. Bohma, O.S. (2017), «Kharakterystyka osnovnykh metodiv upravlinnia biudzhethnoiu bezpekoiu Ukrainy», *Problemy i perspektyvy rozvytku pidpriemnytstva*, No. 1, pp. 41–45.
4. Bohma, O.S. (2017), «Osoblyvosti statychnoho ta dynamichnogo kharakteru katehorii «biudzhethna bezpeka»», *Ahrosvit*, No. 5, pp. 27–30.
5. Borodii, O.A. (2015), «Upravlinnia biudzhethnoiu bezpekoiu Ukrainy», Abstract of PhD dissertation, NTUTs, Chernihiv, 20 p.
6. Chumak, V.V. (2014), «Teoretyko-pravovyi analiz poniat «natsionalna bezpeka» i «derzhavna bezpeka»», *Pravnychiy visnyk Universytetu «KROK»*, No. 20, pp. 95–103.
7. Svirko, S., Moshenskyi, S. and Butuzov, V. (2022), «Genesis of the state management of budget security», *Socio World-Social Research & Behavioral Sciences*, Vol. 09, Iss. 03, pp. 74–81.
8. Dets, V.F. (2007), «Biudzhethna bezpeka ta kryterii yii otsynky», *Stratehichna panorama*, No. 3, pp. 157–160.
9. Demenok, O.V. and Hlukhova, V.I. (2010), «Biudzhethna bezpeka Ukrainy yak skladova finansovoi bezpeky derzhavy: stan ta perspektyvy», *Nauka y ekonomika, Finansova systema*, No. 1 (17), 20 p.
10. *Harvard National Security Journal*, [Online], available at: <https://harvardnsj.org/>
11. Hrytsyshen, D.O., Svirko, S.V. and Suprunova, I.V. (2019), «Biudzhethna bezpeka yak ob'ekt analitychnykh doslidzhen v umovakh reformuvannia systemy upravlinnia mistsevymy biudzhethamy», *Investysii: praktyka ta dosvid*, No. 24, pp. 129–134.
12. Yakovenko, T.M. (2017), «Pravovi mekhanizmy upravlinnia biudzhethnoiu bezpekoiu», *Zakarpatski pravovi chytannia*, No. 1, pp. 225–231.
13. Jayakumar, S. (2020), *State, Society and National Security: Challenges and Opportunities in the 21st Century*, S Rajaratnam School of International Studies, NTU, Singapore, 296 p.
14. Yevdokymov, V.V., Svirko, S.V. and Suprunova, I.V. (2020), «Identyfikatsiia skladovykh derzhavnoi bezpeky yak ob'ektiv derzhavnogo upravlinnia», *Derzhavne upravlinnia: udoskonalennia ta rozvytok*, No. 12, [Online], available at: [http://www.dy.nayka.com.ua/pdf/12\\_2020/6.pdf](http://www.dy.nayka.com.ua/pdf/12_2020/6.pdf)
15. Yevdokymov, V.V. and Svirko, S.V. (2020), «Biudzhethnyi kodeks Ukrainy yak osnovnyi instrument normatyvno-pravovoho suprovodu derzhavnogo upravlinnia biudzhethnoiu bezpekoiu», *Naukovi perspektyvy*, No. 3, pp. 191–203.
16. Yevdokymov, V.V., Svirko, S.V. and Tarasova, T.O. (2021), «Obgruntuvannia poniatynoi osnovy ta struktury derzhavnoi bezpeky yak ob'ektu derzhavnogo upravlinnia», *Tekhnolohichniy audyt ta rezervy vyrobnytstva*, No. 4/4 (60), pp. 46–51.
17. Kolisnyk, O.Ia. (2011), «Ekonomichna pryroda biudzhethnoi bezpeky derzhavy», *Naukovi zapysky Natsionalnogo universytetu «Ostrozka akademiia»*. Serii *Ekonomika*, No. 16, pp. 369–377.
18. Kovpak, E.V. (2011), «Systemni kharakterystyky biudzhethnoi bezpeky derzhavy», *Naukovyi visnyk Khersonskoho derzhavnogo universytetu*, No. 19, pp. 25–29.
19. Kuts, H.M. (2020), «Kontseptualizatsiia poniat «natsionalna bezpeka» i «derzhavna bezpeka» u polityko-pravovomu dyskursiiu», *Suchasne suspilstvo*, No. 1, pp. 139–153.
20. Lutsyk-Dubova, L. (2013), «Upravlinnia biudzhethnoiu bezpekoiu Ukrainy», *Halyskyi ekonomichnyi visnyk*, No. 3 (42), pp. 17–23.
21. Medvid, M.M. (2017), «Derzhavna ta natsionalna bezpeka: poniatynno-katehorialnyi aparat», *Naukovyi visnyk Lvivskoho derzhavnogo universytetu vnutrishnikh sprav*, No. 2, pp. 74–84.
22. *Inquiries Journal*, «National Security Articles», [Online], available at: <http://www.inquiriesjournal.com/keyword/national-security>
23. *POLITICO*, «NATIONAL SECURITY: News, Analysis and Opinion from POLITICO», [Online], available at: <https://www.politico.com/news/national-security>

24. Osisanya, S. (2016), «National Security versus Global Security», [Online], available at: <https://www.un.org/en/chronicle/article/national-security-versus-global-security>
25. Postolenko, Yu.P. (2011), «Biudzhetsna bezpeka yak kliuchova skladova finansovoi ta ekonomichnoi bezpeky», *Visnyk sotsialno-ekonomichnykh doslidzhen*, No. 3 (43), pp. 121–126.
26. Verkhovna Rada Ukrainy (2018), *Pro natsionalnu bezpeku Ukrainy*, Zakon Ukrainy vid 21.06.2018 r. No. 2469-VIII, [Online], available at: <https://zakon.rada.gov.ua/laws/show/2469-19#Text>
27. Verkhovna Rada Ukrainy (2020), *Pro rishennia Rady natsionalno] bezpeky i oborony Ukrainy vid 14 veresnia 2020 roku «Pro Stratehiiu natsionalnoi bezpeky Ukrainy»*, Ukaz Prezydenta Ukrainy №392/2020 vid 14.09.2020 r., [Online], available at: <https://zakon.rada.gov.ua/laws/show/392/2020#Text>
28. Ministerstvo ekonomichnogo rozvytku i torhivli Ukrainy (2013), *Pro zatverdzhennia Metodychnykh rekomendatsii shchodo rozrakhunku rivnia ekonomichnoi bezpeky Ukrainy*, Nakaz vid 29.10.2013 r. No. 1277, [Online], available at: <https://zakon.rada.gov.ua/rada/show/v1277731-13>
29. Prokaziuk, O.V. (2016), «Biudzhetsna bezpeka derzhavy: sutnist ta osnovni zahrozy», *Finansovyi prostir*, No. 3, pp. 39–47.
30. Serohina, N.O., «Teoretyko-metodolohichni analiz spivvidnoshennia poniat «natsionalna bezpeka», «derzhavna bezpeka» ta «produktivna zaniatist»», *Public Administration and National Security*, [Online], available at: <https://www.inter-nauka.com/uploads/public/15905325328491.pdf>
31. Svirko, S.V. (2021), *Mekhanizmy derzhavnogo upravlinnia biudzhetnoiu bezpekoiu*, monohrafiia, «Buk-Druk», Zhytomyr, 436 p., [Online], available at: <http://eztuir.ztu.edu.ua/bitstream/handle/123456789/7905/Cvirkko.pdf?sequence=1&isAllowed=y>
32. Svirko, S.V. and Tarasova, T.O. (2021), «Biudzhetsna bezpeka: mistse ta rol v suchasnomu mekhanizmi derzhavnogo upravlinnia», *Visnyk KhNAU im. V.V.Dokuchaieva*, No. 1, pp. 257–273.
33. Zveruk, L.A. and Bilyk, O.H. (2017), «Biudzhetsna bezpeka yak vazhlyvyi priorytet rozvytku biudzhetnoi systemy Ukrainy», *Mizhnarodnyi naukovyi zhurnal «Internauka». Seriiia Ekonomichni nauky*, No. 2, pp. 35–39.